

Detex Corporation, 302 Detex Drive, New Braunfels, Texas 78130-3045
 (830)629-2900 / 1-800-729-3839 / Fax (830)620-6711
 E-MAIL: detex@detex.com INTERNET: www.detex.com

INSTALLATION INSTRUCTIONS FOR ARCHITECTURAL VALUE SERIES® AND "H" MODELS (HURRICANE)

V4000 Architectural VALUE SERIES® Exit Device

U.S. PATENT NUMBERS:

6009732

6205825B1

6532777B2

INTERNATIONAL PATENT NUMBER:

PCT6009732

Parts Check List

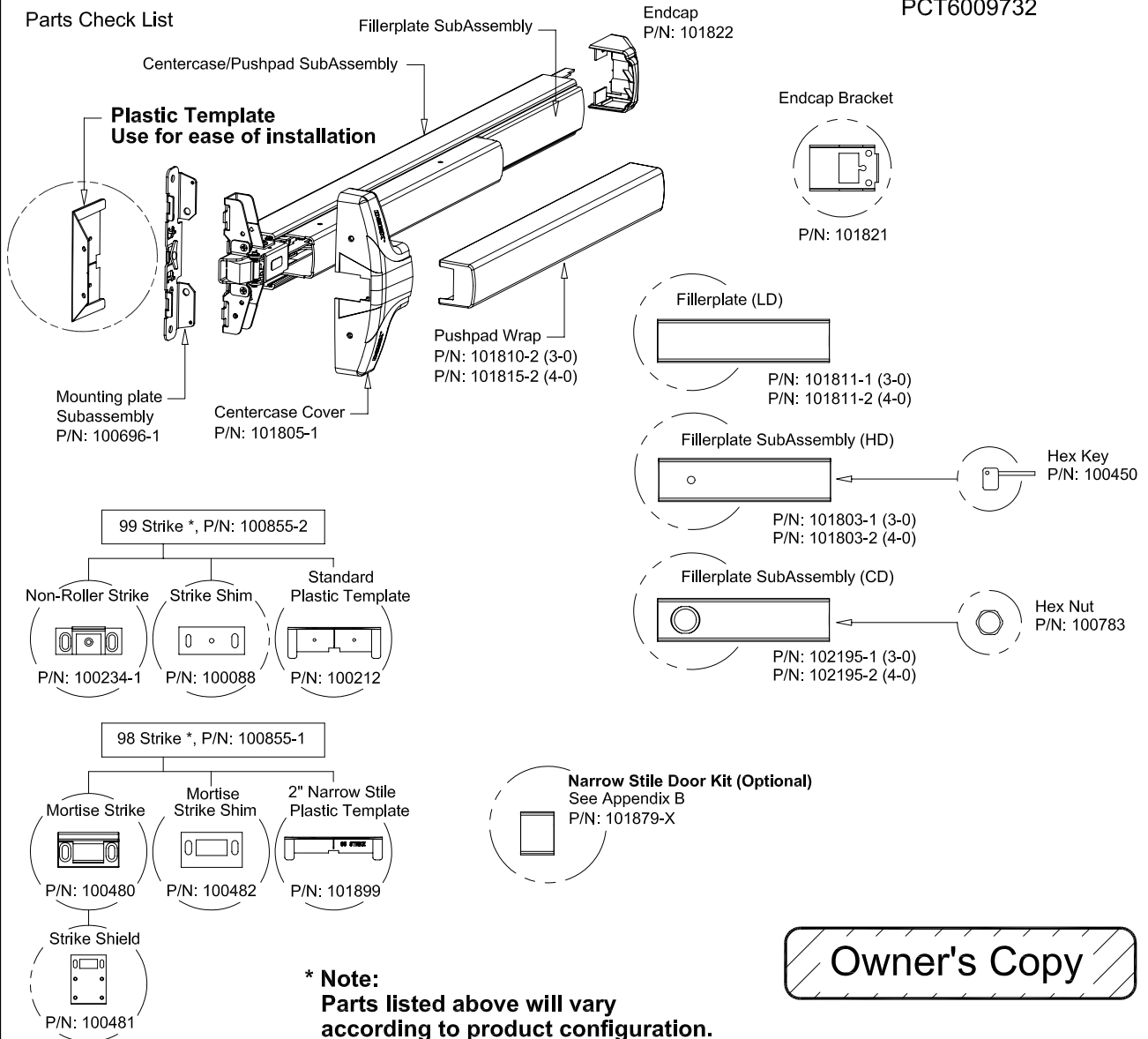

*** Note:**
Parts listed above will vary according to product configuration.

Owner's Copy

Detex Value Series® panic hardware, when properly installed, used and maintained, is warranted to be free of defects in material and workmanship. We will, for a period of three (3) years from the date of purchase, repair or replace any part which, upon our examination, proves to be defective under normal use. This warranty will be honored only upon presentation of proof that the product covered thereby was purchased directly from an authorized Detex distributor. WE SHALL NOT BE LIABLE FOR ANY DIRECT, INCIDENTAL OR CONSEQUENTIAL LOSS OR DAMAGE ARISING OUT OF THE FAILURE OF THIS PANIC HARDWARE TO OPERATE.

!!!CHECK BEFORE STARTING!!!

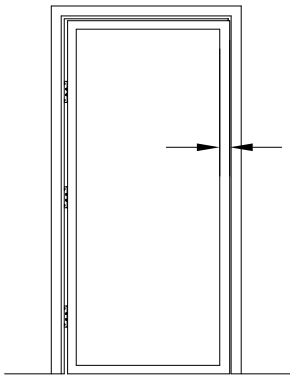

Wide Stile (Surface Strike)
Minimum door stile 4-1/2" (114 mm) Template drawings provide door and frame structural and dimensional specifications for door and frame preparation.
Narrow Stile
Minimum door stile 2" (51mm) Surface strike possible Mortise strike recommended

Doors and frames with walls having a structural thickness (metal skin plus reinforcement, or solid wood) to engage less than (3) full screw threads, are considered unreinforced for hardware.

Unreinforced Doors: Use Sex Nuts and Bolts
Unreinforced Frames: Use Blind Rivet Nuts (see sketch)
Fasteners for unreinforced openings are not supplied by Detex.

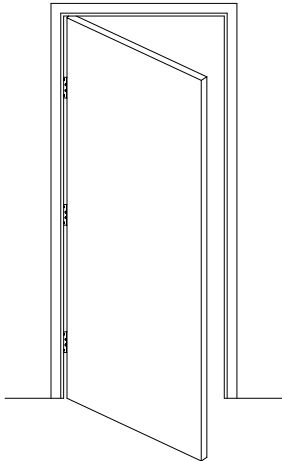
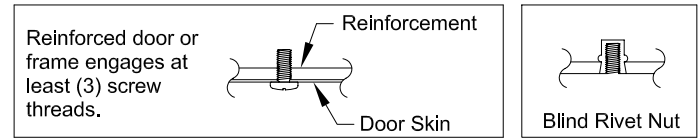

Door Must Swing Freely

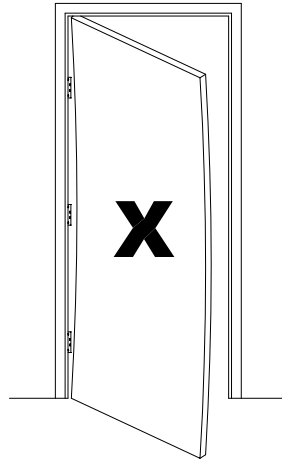

Door Must Not be Warped

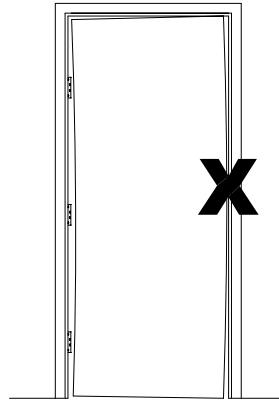

Door Must Not Bind

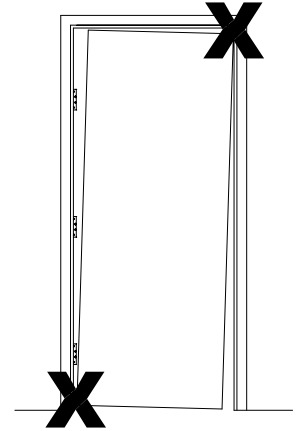





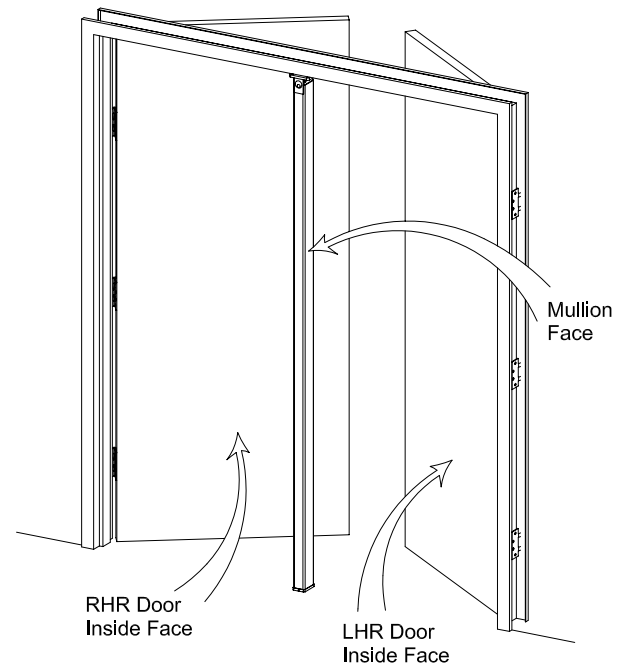
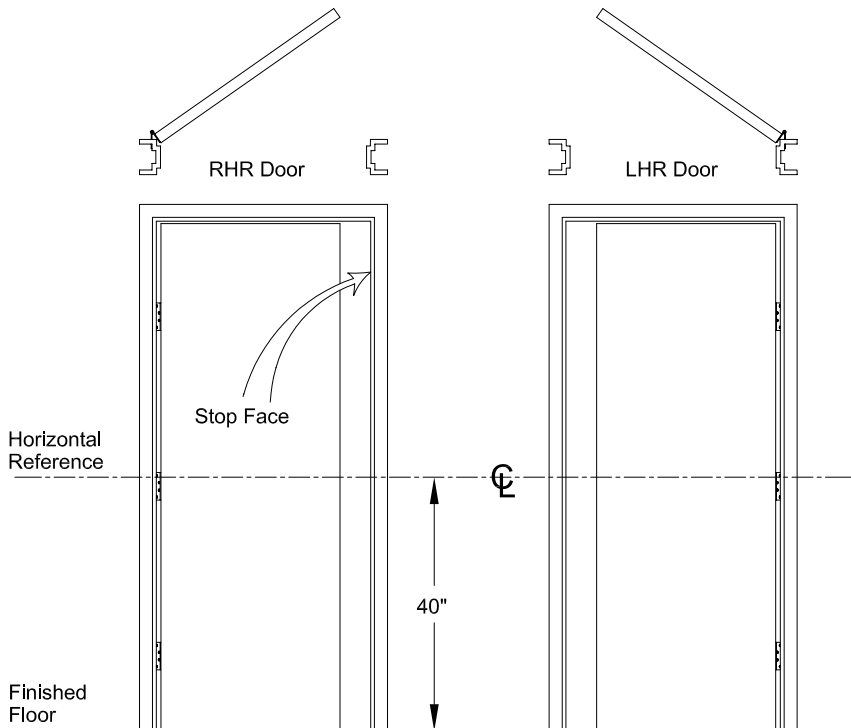

Door Must Not Sag

NOTE: 750mm MAXIMUM DOOR WIDTH OPENING FOR EUROPE FOR 36" DEVICE
(1000mm MAXIMUM DOOR WIDTH OPENING FOR EUROPE FOR 48" DEVICE)
THE SAFETY FEATURES OF THIS PRODUCT ARE ESSENTIAL TO ITS COMPLIANCE WITH EN 1125.
NO MODIFICATION OF ANY KIND, OTHER THAN THOSE DESCRIBED IN THESE INSTRUCTIONS ARE PERMITTED.

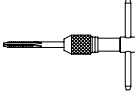



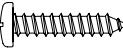
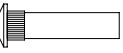

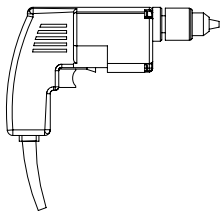

Fastener Table

			Drill Bit	Tap Wrench	Comments
					Use Either Machine Screws, Sheetmetal Screws, or Sex Nuts
Machine Screws 	#6-32 x 5/8"	PPH	#36 or 7/64	#6-32 Tap	Used on 98 Strike Shield Mounting Holes
	#6-32 x 3/8"	PPH	----	----	Used to Mount Centercase Cover and Endcap
	#10-24 x 5/8"	PPH	#25 or 9/64"	#10-24 Tap	Used on 99 Strike Center Mounting Hole
	#1/4-20 x 1/4"	PPH	----	----	Used to Fasten Centercase Unit onto Mounting plate
	#1/4-20 x 1"	PPH	#7 or 13/64"	#1/4-20 Tap	Used on Strike, Mounting plate, and Endcap Mounting Holes
Sheetmetal Screws 	#6 x 1"	PPH	9/64"	----	Used on 98 Strike Shield Mounting Holes
	#10 x 1"	PPH	#22 or 5/32"	----	Used on 99 Strike Center Mounting Hole
	#14 x 1-1/4"	PPH	7/32"	----	Metal Applications Used on Strike, Mounting plate, and Endcap Mounting Holes
		PPH	3/16"	----	Wood Applications Used on Mounting plate, and Endcap Mounting Holes
Sex Nut 	#1/4-20	----	9/32" Interior Door Face	----	Recommended on Fire Rated Wood and Unreinforced Hollow Metal Doors Used on Mounting plate and Endcap Mounting Holes
		----	3/8" Exterior Door Face	----	
	#10-32	----	13/64" Interior Door Face	----	Recommended on Fire Rated Wood and Unreinforced Hollow Metal Doors Used on Strike Hook Mounting Holes
		----	5/16" Exterior Door Face	----	

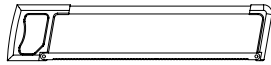
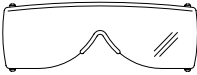
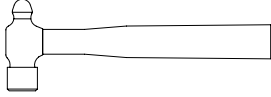
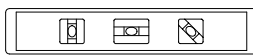
Note: (1) Fastener selection will vary per catalog configuration and kits ordered.
 (2) Mortise cylinder NOT provided.

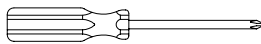
Tools Required

Power Drill 	Pencil 
	Hack Saw 
Safety Glasses 	Hammer 
Level 	Tape Measure 
Screw Driver 	Center Punch 

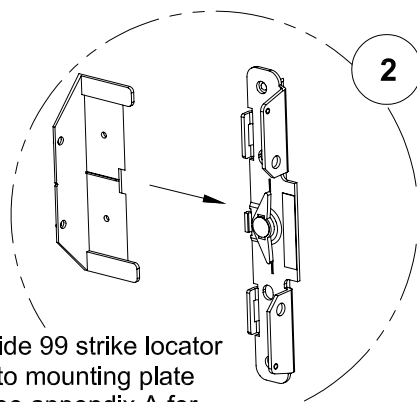

2
Slide 99 strike locator into mounting plate (see appendix A for 98 strike and strike hook installation)

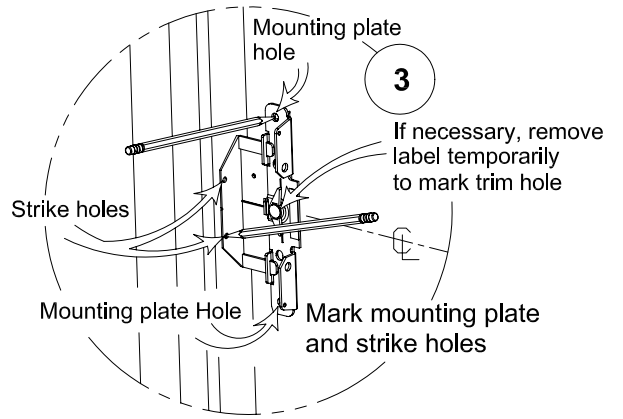

3
If necessary, remove label temporarily to mark trim hole
Mark mounting plate and strike holes

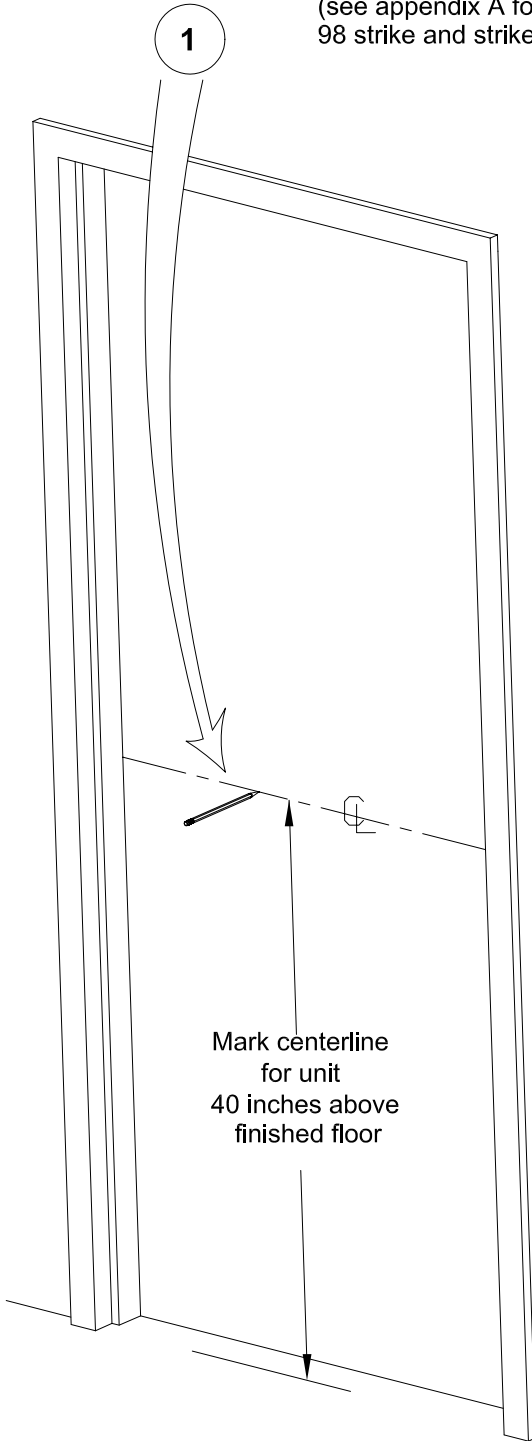

1
Mark centerline for unit 40 inches above finished floor

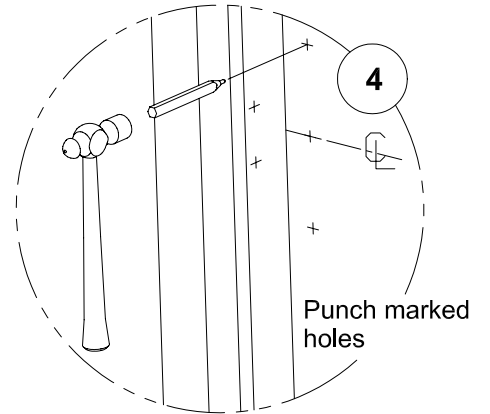

4
Punch marked holes

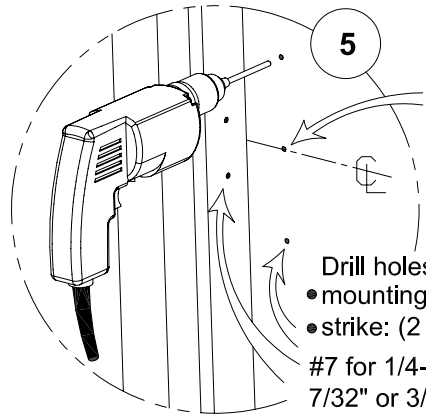

5
Trim input hole if necessary. (see outside trim instructions)
Drill holes
• mounting plate: (2 pl)
• strike: (2 pl)
#7 for 1/4-20 machine screws
7/32" or 3/16" for #14 sheetmetal screws
(see fastener table)

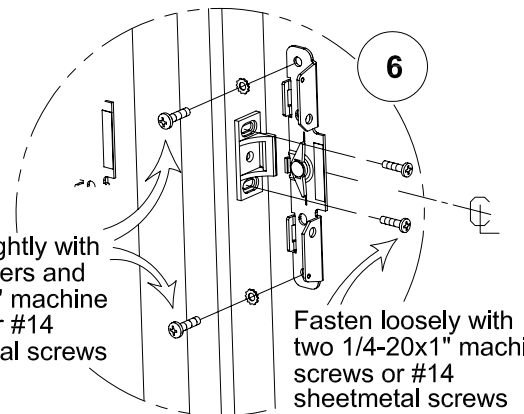

6
Fasten tightly with lockwashers and 1/4-20x1" machine screws or #14 sheetmetal screws
Fasten loosely with two 1/4-20x1" machine screws or #14 sheetmetal screws

Depress pushpad
when installing

1

Position cam
as shown

Insert centercase
guides into slots
of mounting plate

2

Rotate device
toward door

HURRICANE MODELS

NOTE:
Hurricane models
require TWO
additional screws
(See hurricane kit)

Fasten rim device
to mounting plate
and door with
1/4-20x1" machine
screws or #14
sheetmetal screws

3

Fasten rim device
to mounting plate
with 1/4-20 x 1/4" PPH
machine screws

CHECKING FOR DEVICE CLEARANCE

(Cut-Off procedure if required)

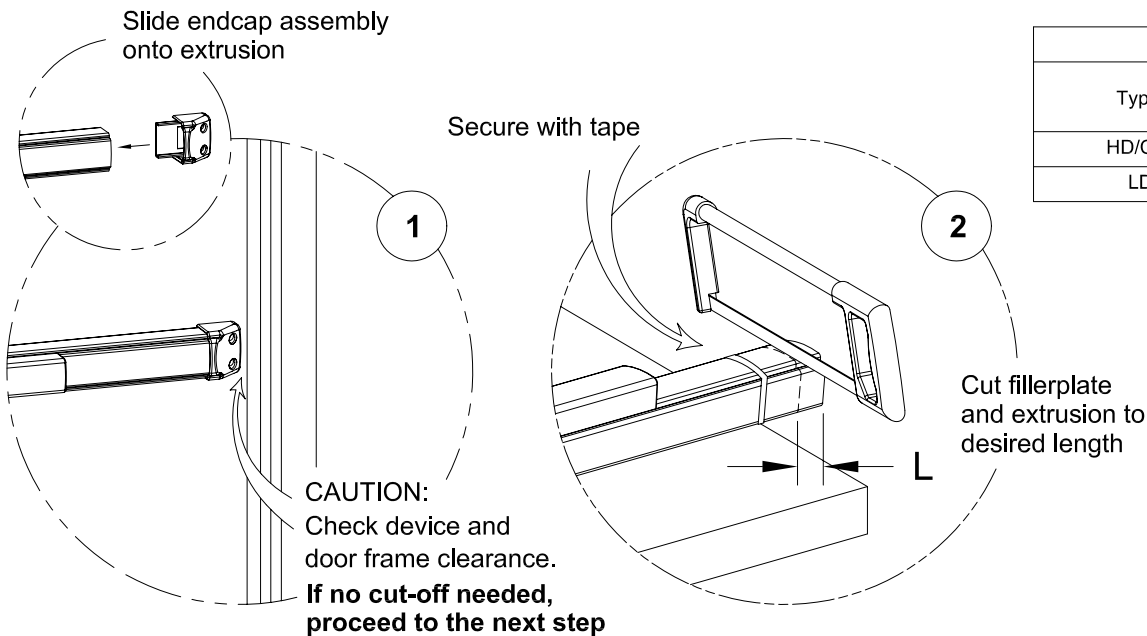

Type	Max Cut-Off	
	Length (L)	
HD/CD	36" Unit 6 in	48" Unit 12 in
LD	6-3/4 in	12-3/4 in

INSTALL MORTISE CYLINDER IF REQUIRED (V4000 x CD)

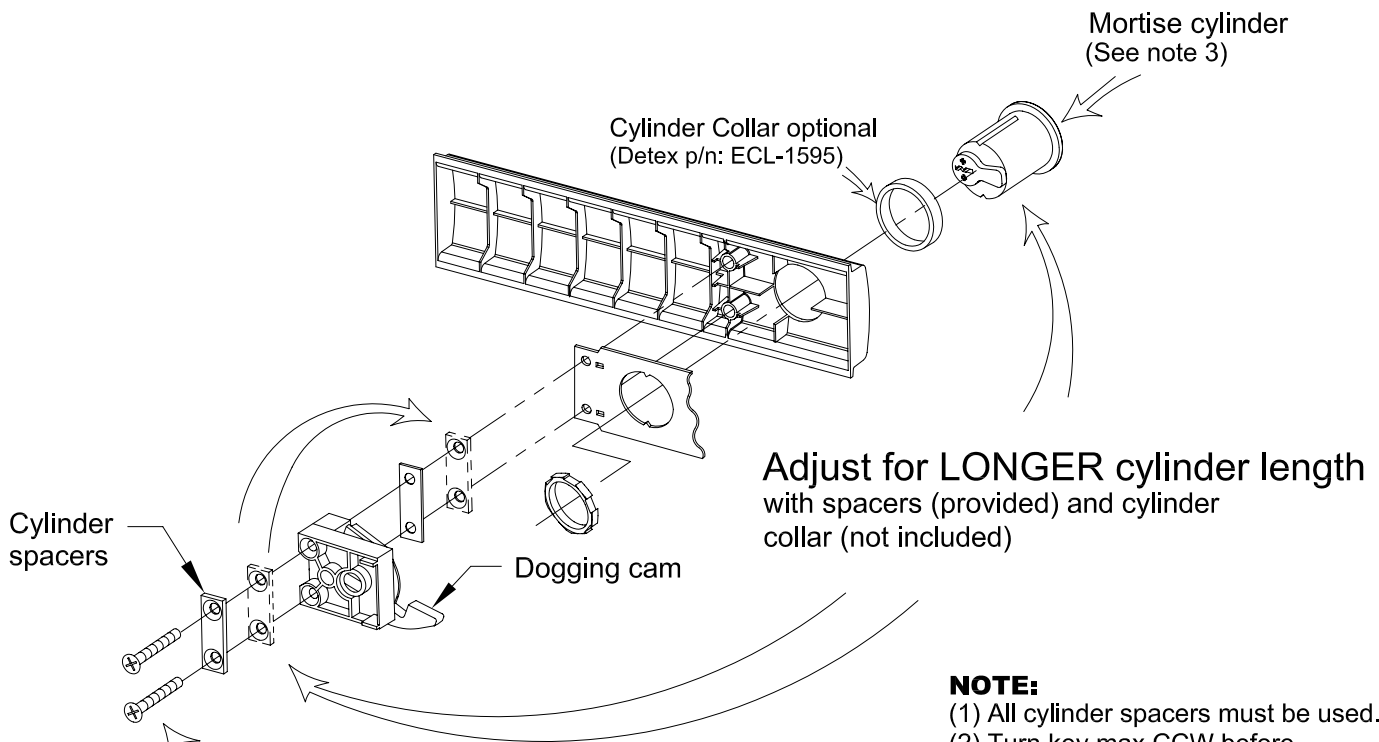

CAUTION:
Tighten with hand tools only.
Do not overtighten

- NOTE:**
- (1) All cylinder spacers must be used.
 - (2) Turn key max CCW before installing slide in fillerplate.
 - (3) Use a cylinder collar when installing a 7-pin mortise cylinder.
 - (4) Reinstall fillerplate subassembly

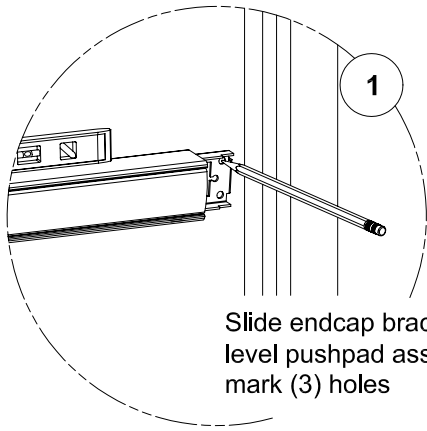

1
Slide endcap bracket into extrusion, level pushpad assembly, and mark (3) holes

Note: Endcap bracket must bottom-out on extrusion before marking holes.

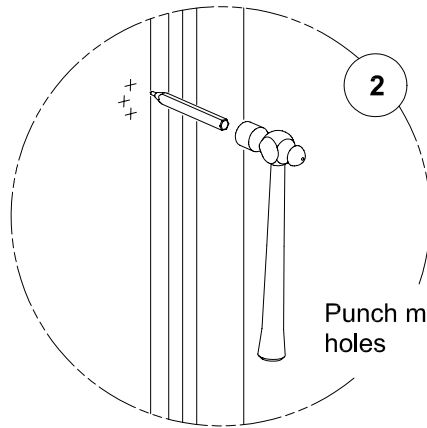

2
Punch marked holes

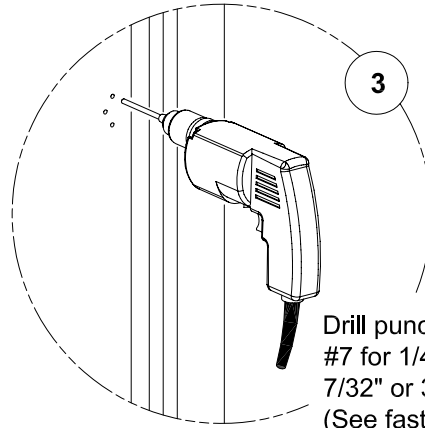

3
Drill punched holes
#7 for 1/4-20 machine screws
7/32" or 3/16" for #14 sheetmetal screws
(See fastener table)

IMPORTANT NOTE:

Screw prevents endcap tampering.

Loosely fasten

with lockwasher and either 1/4-20x1 machine screw or #14 sheetmetal screw (see fastener table)

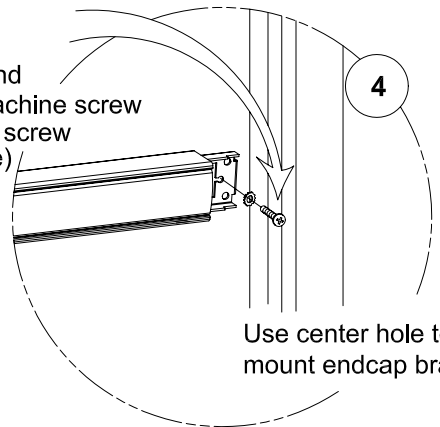

4
Use center hole to mount endcap bracket

IMPORTANT:

Install (2) 6-32 FH screws for added security

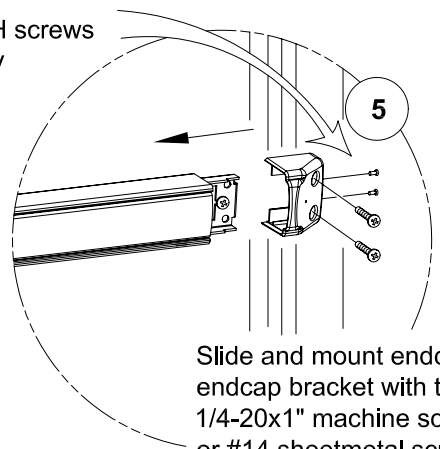

5
Slide and mount endcap to endcap bracket with two 1/4-20x1" machine screws or #14 sheetmetal screws

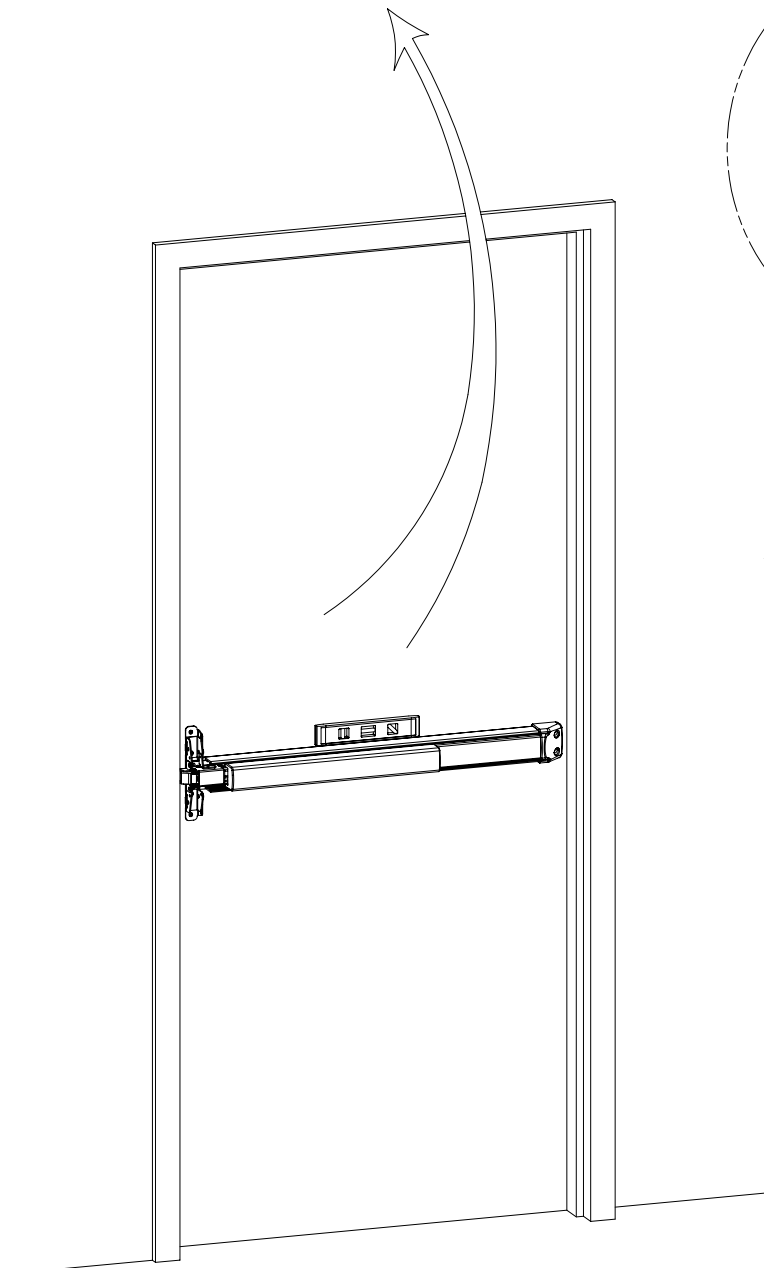

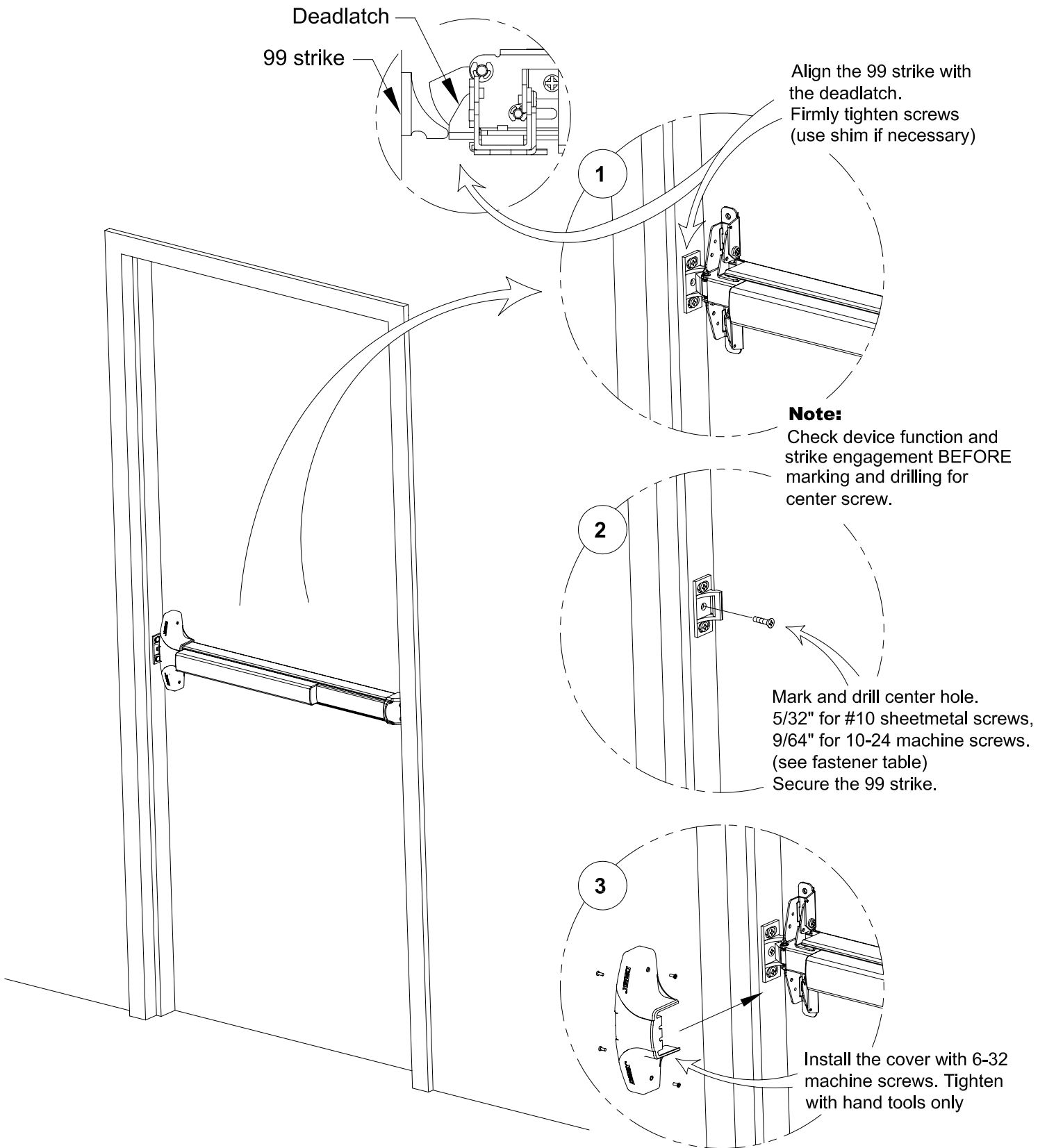

Care and Maintenance:

The Detex Value Series® devices are designed to provide many years of maintenance free service under normal usage. Periodically inspect and lubricate the unit to extend its life.

Appendix A

98 STRIKE INSTALLATION

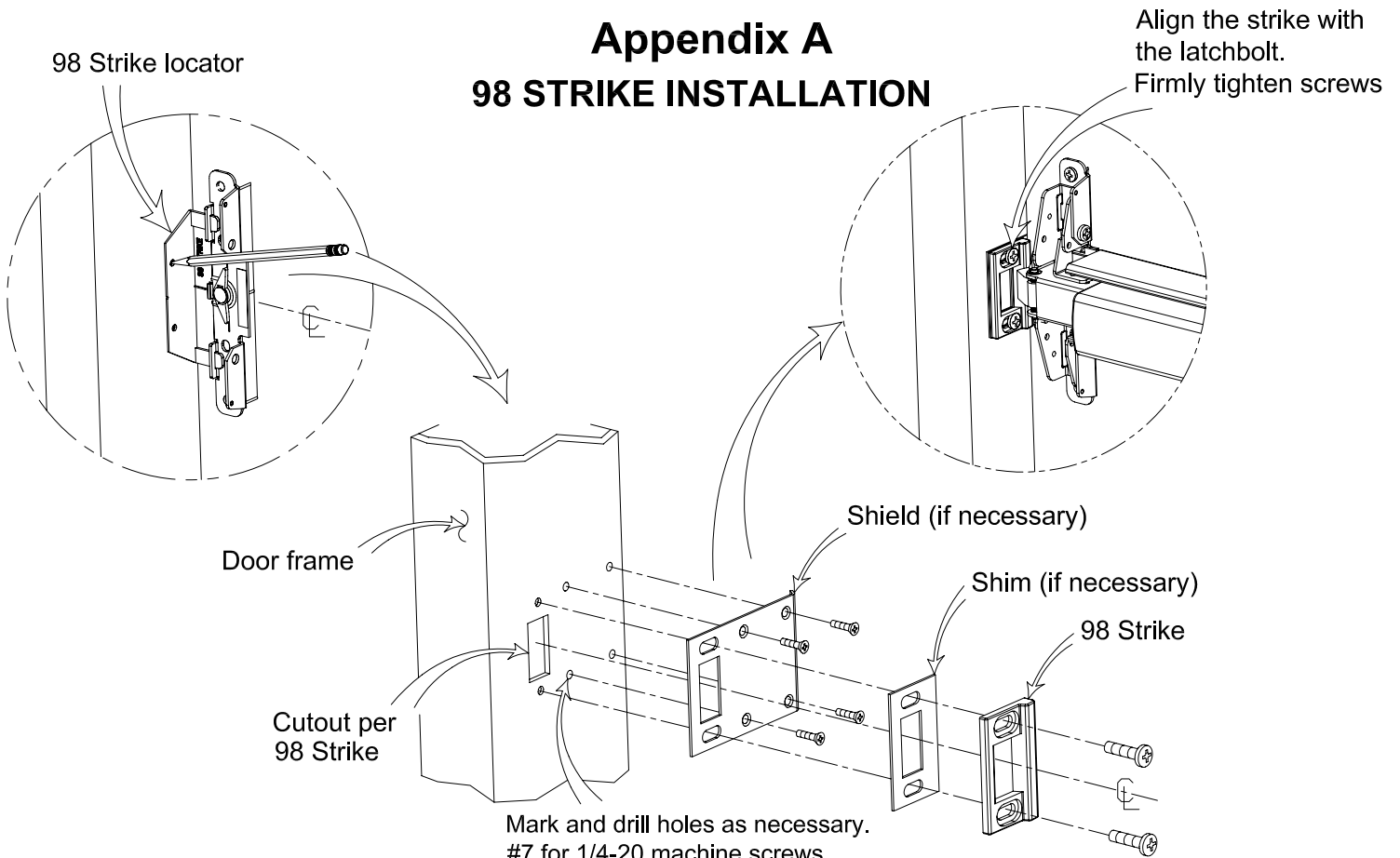



Mark and drill holes as necessary.
 #7 for 1/4-20 machine screws,
 7/32" or 3/16" for #14 sheetmetal screws
 7/64" for 6-32 machine screws,
 9/64" for #6 sheetmetal screws
 (see fastener table)

STRIKE HOOK INSTALLATION

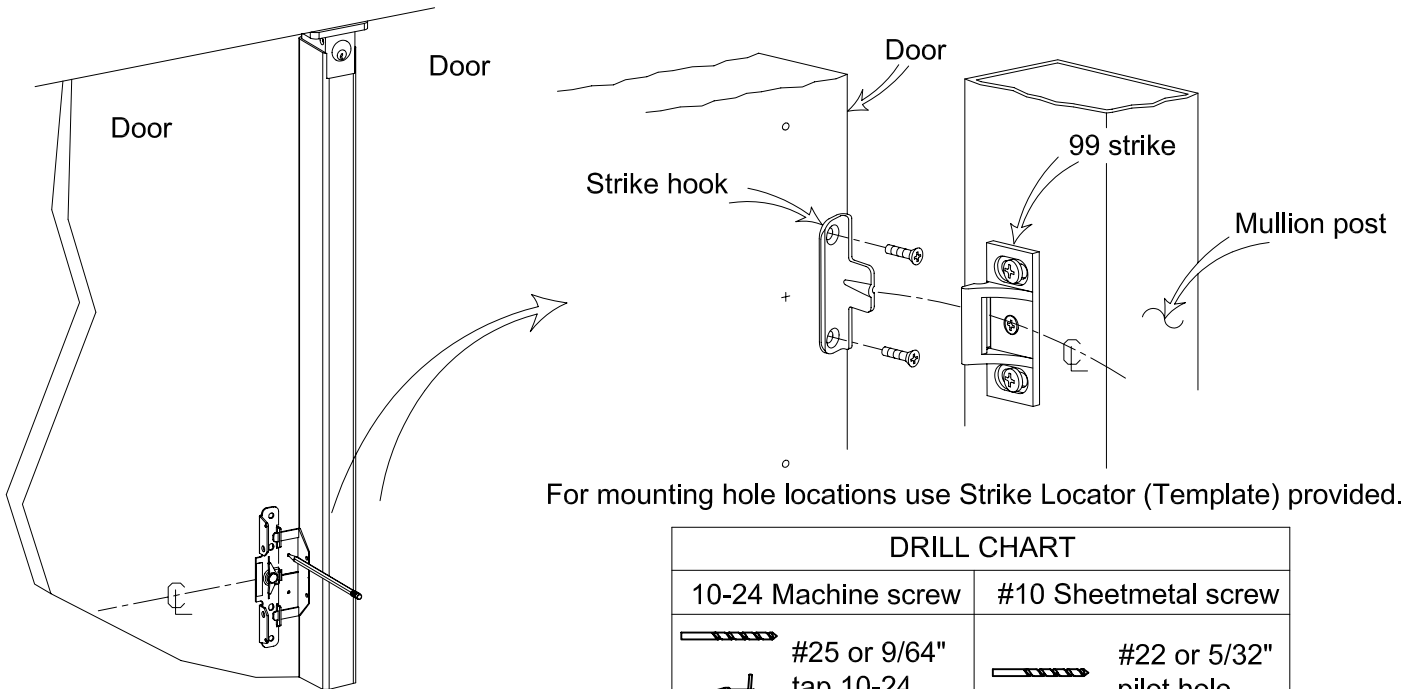
(Caution: This installation is required on fire rated door openings with removable mullion.)



For mounting hole locations use Strike Locator (Template) provided.

DRILL CHART	
10-24 Machine screw	#10 Sheetmetal screw
 #25 or 9/64"	 #22 or 5/32"
 tap 10-24	pilot hole

Appendix B

Optional Accessories

Glass Bead Kit

Catalog No: GB15

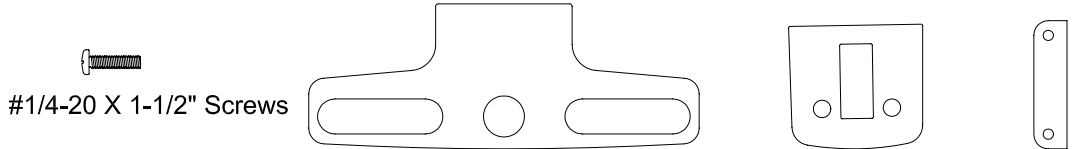

#1/4-20 X 1-1/2" Screws

Sex Nut

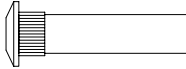

The #10-32 kit is available in (4) finishes:

- Catalog No: SN2 Brushed Brass BHMA 606 Finish
- Catalog No: SN2 Oil Rubbed Bronze BHMA 613 Finish
- Catalog No: SN2 Brushed Chrome BHMA 626 Finish
- Catalog No: SN2 Stainless Steel BHMA 630 Finish

The #1/4-20 kit is available in (4) finishes:

- Catalog No: SN1 Brushed Brass BHMA 606 Finish
- Catalog No: SN1 Oil Rubbed Bronze BHMA 613 Finish
- Catalog No: SN1 Brushed Chrome BHMA 626 Finish
- Catalog No: SN1 Stainless Steel BHMA 630 Finish

Tamper Kit

(Security Kit)

Catalog No: SSK3

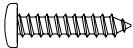

Security Screws

Security Pin TORX® Bits provided

Narrow Stile Door Kit

(Splice Kit may be used with either 3-0 or 4-0 units)

Catalog No: NSK1 (628 Finish, Clear)

Catalog No: NSK1 (711 Finish, Black)

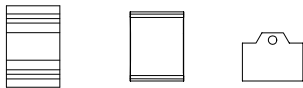

Double Door Strike Kit

Catalog No: 94 with security screws

Catalog No: 95 with standard screws

